

CAMBRIDGE INTERNATIONAL EXAMINATIONS

Cambridge International Advanced Subsidiary and Advanced Level

MARK SCHEME for the October/November 2014 series

9691 COMPUTING

9691/11

Paper 1 (Written Paper), maximum raw mark 75

This mark scheme is published as an aid to teachers and candidates, to indicate the requirements of the examination. It shows the basis on which Examiners were instructed to award marks. It does not indicate the details of the discussions that took place at an Examiners' meeting before marking began, which would have considered the acceptability of alternative answers.

Mark schemes should be read in conjunction with the question paper and the Principal Examiner Report for Teachers.

Cambridge will not enter into discussions about these mark schemes.

Cambridge is publishing the mark schemes for the October/November 2014 series for most Cambridge IGCSE[®], Cambridge International A and AS Level components and some Cambridge O Level components.

® IGCSE is the registered trademark of Cambridge International Examinations.

Page 2	Mark Scheme	Syllabus	Paper
	Cambridge International AS/A Level – October/November 2014	9691	11

1 (i) Any **one** point from:

- directs and coordinates all other parts of the computer system
- controls and directs operations of the computer system
- fetches/retrieves computer instructions (in sequence)
- decodes/interprets each instruction
- then directs other parts of computer system in their implementation/execution [1]

(ii) Any **one** from:

- all the data and instructions computer needs/is using are stored here
- contains RAM/ROM [1]

(iii) Any **one** from:

- unit which performs arithmetic operations
- and bit shifting operations
- and logic operations (such as AND, OR, XOR (etc.))
- designed to perform integer calculations [1]

2 (a) (i) Any **two** points from:

- obsolescence/out of date
- specific examples e.g. floppy disk, mag tape etc.
- not compatible with new equipment
- key components no longer manufactured/spares are hard to find
- software support no longer in existence/problems with maintenance [2]

(ii) Any **two** points from:

- upgrading/updating of system (using parts which are outside normal specified range)
- buying enough spare parts to meet system's forecasted lifetime requirements
- part substitution (different parts with similar fit are used where possible)
- redesign system to allow introduction of new components
- emulation (parts with identical function and fit are made from new technologies)
- aftermarket sources (third parties continue to make "obsolescent" parts)
- training in-house programmers/maintenance personnel [2]

(b) Any **six** points from:

- corrective ...
- ... solve any bugs/problems in the software
- adaptive ...
- ... alter the solution to take into account changes in external influences (e.g. new airport legislation, new international safety rules, etc.)
- perfective ...
- ... alter the solution to improve the overall performance [6]

Page 3	Mark Scheme	Syllabus	Paper
	Cambridge International AS/A Level – October/November 2014	9691	11

3 (a) 1 mark per point. Maximum of 3 marks for baseband and maximum of 3 marks for broadband

baseband

- data sent as digital signals
- through the media as a single channel
- that uses entire bandwidth of the media/one frequency
- it is bi-directional
- (frequency-division) multiplexing is not possible

broadband

- data sent in form of analogue signals
- each transmission is assigned to a portion of the bandwidth
- thus multiple transmissions are possible at the same time
- communication is uni-directional
- to send and receive needs two pathways
- either by assigning a frequency for sending and a different frequency for receiving
- or by using different communication paths/wires
- multiplexing is possible using this method

[4]

(b)

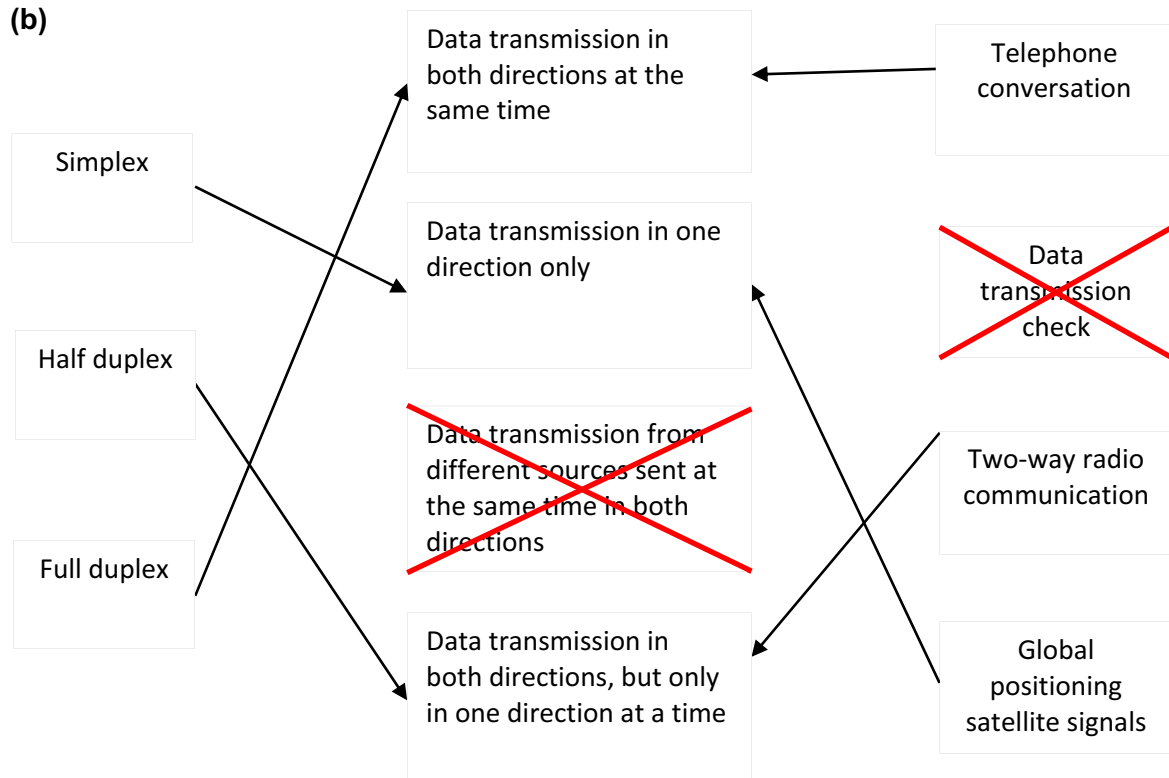

(1 mark for each correct connection)

[6]

Page 4	Mark Scheme	Syllabus	Paper
	Cambridge International AS/A Level – October/November 2014	9691	11

4 (a) – a program that can self-replicate
 can delete or corrupt data from a computer system
 malicious code often installed without the user's knowledge [1]

(b) Any **three** from:

- install and run/use anti-virus software
- update anti-virus software on a regular basis
- avoid programs/software/downloads from unknown sources
- never “double click” on email attachments which are executable i.e. contain .exe, .com or .vbs
- install and run/use a firewall (which screens incoming Internet and network traffic)
- install and run/use anti-spyware software (which works in conjunction with the anti-virus to stop viruses doing any harm to the computer)
- avoid suspicious web sites
- delete emails from unknown contacts without opening
- avoid using media from unknown sources [3]

5 (a) 107 [1]

(b) (i) – 2 dimensional
 – array [2]

(ii) Each correct answer (shown in bold (red)) = 1 mark

DECLARE BinaryNumber [2, 8]: **array** OF INTEGER

PlaceValue ← 128

FOR index ← 1 TO **8**

INPUT BinaryNumber [2 , **Index**]

BinaryNumber [**1** , Index] ← PlaceValue

PlaceValue ← PlaceValue / 2

ENDFOR

[4]

6 (a)

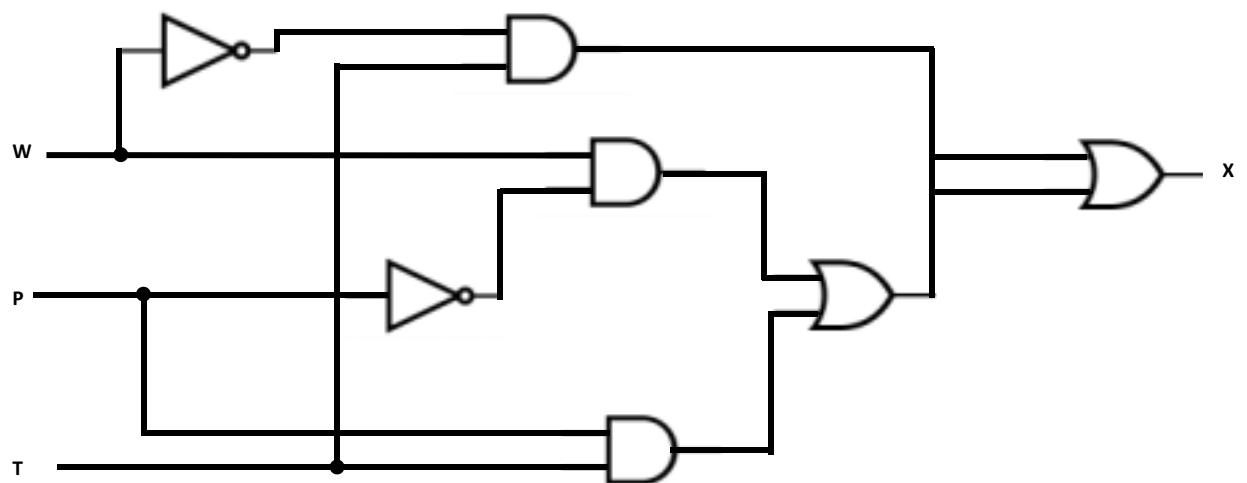

(corresponds to: $[W = 1 \text{ AND } P = \text{NOT } 1] \text{ OR } [T = 1 \text{ AND } P = 1] \text{ OR } [W = \text{NOT } 1 \text{ AND } T = 1]$)

1 mark for each correct logic gate in correct position – [7]

(b)

input W	input P	input T	output X	
0	0	0	0	1 mark
0	0	1	1	
0	1	0	0	1 mark
0	1	1	1	
1	0	0	1	1 mark
1	0	1	1	
1	1	0	0	1 mark
1	1	1	1	

[4]

Page 6	Mark Scheme	Syllabus	Paper
	Cambridge International AS/A Level – October/November 2014	9691	11

7 (a) **noise**

- microphone
- sound sensor/detector

air pollution

- NO_x monitor/sensor/detector
 - CO₂ monitor/sensor/detector
- [2]

(b) Any **one** from:

- use portable devices (to download data each month from solid state memory)
 - transmit data to remote computer at research site automatically over cellular network
 - use a telephone network and manually connect to data logger and request it to send data over internet link
- [1]

(c) Any **three** from:

- use of macros...
 - in spreadsheets and databases
 - most recent data compared to last 2 or 3 months data already stored in database or spreadsheet
 - new data loaded into spreadsheet
 - graphs drawn showing results over last 2 or 3 months
 - graphs produced showing results for every month over last 4 years
 - compare results/graphs with “normal” data
 - use of “average” or “trend” function on graphs
 - use of “rolling average” to show changes over long period
 - use data to predict noise and air pollution levels in 5 years, 10 years ... time
- [3]

8 (i) CLI uses a keyboard to allow user to key in commands such as load a file/mouse and touch screens are used in GUI environment where icons represent applications to be launched [1]

(ii) the two binary numbers have **odd values** (113 and 147) but actually have **even parity** (both binary numbers have four 1s) [1]

(iii) central heating systems need to respond quickly to changes in temperature so need to run in real time/batch processing would not allow a fast/immediate response [1]

(iv) WANs require external connections which are usually through telephone lines/devices inside buildings (such as routers, modems, ...) can operate using Wi-Fi connections but these devices need to link to the outside world via wired telephone connections [1]

(v) stacks only permit *last in first out (lifo or filo)* principle/structures that use *fifo* are usually called queues [1]

Page 7	Mark Scheme	Syllabus	Paper
	Cambridge International AS/A Level – October/November 2014	9691	11

- 9 (a) 1 mark for device + 1 mark for reason
- touch screen – easy to use in a garage environment
 - easier navigation
 - more difficult to input incorrect data into system
- [2]

(b) Any **three** from:

- expert system asks further questions
 - ... based on response to earlier questions
 - mechanic inputs further symptoms/faults
 - expert system uses inference engine to
 - search the knowledge base
 - using the rules base
 - to find faults that match symptoms/faults input
 - gives % probability that each solution is correct
 - suggests what mechanic should do next
- [3]

(c) Any **two** from:

- use live data/test where faults known
 - input data with known outcomes
 - compare expert system results with actual results from live data
 - if different results, experts system is amended
 - if results within acceptable range, try out new data and see how successful system is
 - test data should be very varied to test all possible scenarios
- [2]

10 (a)

Question	True	False
Custom-written software takes a long time to develop	✓	
Custom-written software isn't fully tested		✓
Custom-written software won't have any technical backup		✓
Off-the-shelf software is usually cheaper because costs are shared	✓	
Off-the-shelf software is always compatible with other software		✓

[4]

Page 8	Mark Scheme	Syllabus	Paper
	Cambridge International AS/A Level – October/November 2014	9691	11

(b) 1 mark for each benefit + 1 mark for a description

off-the-shelf:

- off-the-shelf software probably has an already trained work force
 - therefore training costs are saved
- off-the-shelf software has many user groups/blogs to gain advice/help
 - therefore more likely to get help if a problem occurs
- a wide diversity of users ensures off-the-shelf software is fully tested under a number of different scenarios ...
 - less likely to encounter problems
- version xxx is probably already on the market
 - upgrades will become available throughout the life of the software without having to pay for any further development

custom-written:

- custom-written software does not contain unwanted features
 - therefore easier to use and more efficient running
- custom-written software can be written to interface with all the company's existing software
 - off-the-shelf software will only be tested against widely available software; the company may have specialist software on its system which will not have been tested with off-the-shelf software

[4]

(c) Any **four** from:

- purpose of the system
- how to (load and) run the software
- how to save (files)
- how to carry out a search
- how to sort the data
- how to add/delete/amend (records)
- screen layouts (input and output)
- software requirements
- sample runs (with test data and test results)
- error handling/meaning of errors
- troubleshooting guide/FAQs
- tutorials
- licence agreement/warranty agreement
- customisation

[4]